

WINDEX[®] 10 -SPORT

INSTRUCTIONS

WINDEX 10.SPORT is a 10" Windex wind vane for small keel boats, sport-boats and dinghies

Windex 10.Sport features sapphire suspension bearing for super low friction and extra sensitivity. 10" vane (25.4 cm) pivots atop support shaft, which mounts adjustable tacking arms with tabs. Vane and tabs have reflective surfaces for high visibility day and night. Windex 10.Sport includes glass reinforced polycarbonate J-Base for mounting on side, top or front of mast. J-Base fits masts of most small boats and dinghies. Installs with two #10 (5 mm) self-tapping screws, included.

Windex 10.Sport stands just 9.25" (23.5 cm) tall and weighs only 1.2 ounces (31 g). Responds in wind as low as 2/10 knot—wind tunnel tested to 80 knots.



INSTALLATION

1. Adjust Tab Angle.

Adjust tab arm angle using the template below. Adjust the angle to match upwind performance:

55° for boats with good windward performance

60° for normal ocean racers

65° for normal day cruisers

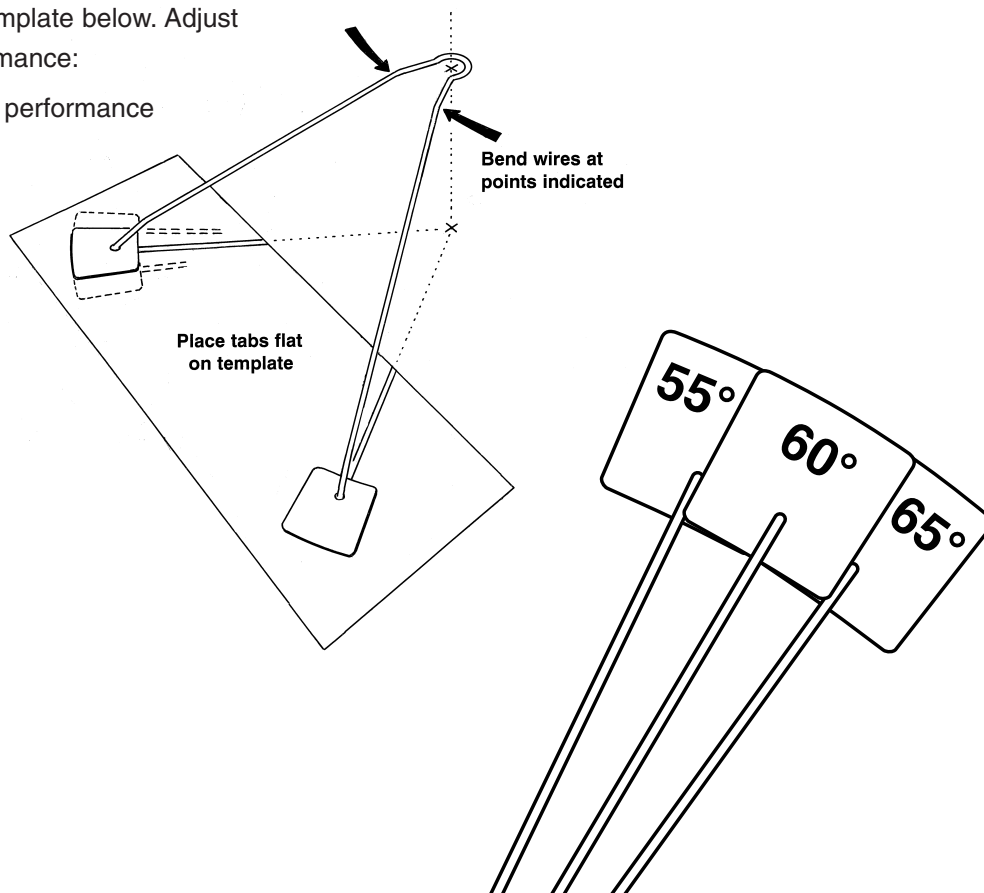

2. Attach vane and tacking arm to support shaft.

Follow these steps:

- Slide crook of tab assembly wire over vane threads.
- Apply silicone sealant or Loctite® to vane threads. Thread support shaft onto vane.
- Completely tighten with wrench until snug.

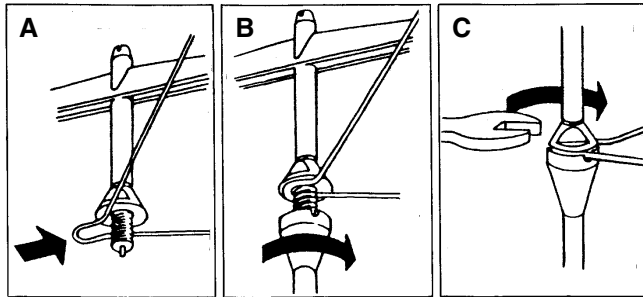

3. Install the J-Base.

At the top of the mast, mount the J-Base horizontally or vertically. The J-Base comes with two #10 (5 mm) self-tapping screws. Drill a pilot hole in the mast, apply silicone sealant or Loctite® and screw into mast. Installation of J-Base can also be accomplished by tapping the mast for 3/16" (5 mm) machine screws or by using epoxy putty to affix the base to the mast. Use silicone sealant on all threaded parts.



4. Go aloft and complete installation.

Tab angle should be preset at approximately 55, 60, or 65 degrees, depending on upwind performance (see step 1). Align Windex with centerline of boat. Apply silicone sealant or Loctite® to the set screw and tighten.

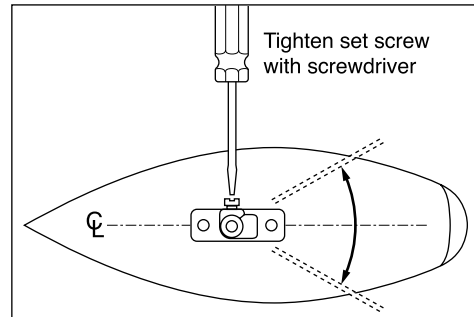

Vane positions at different apparent wind angles:

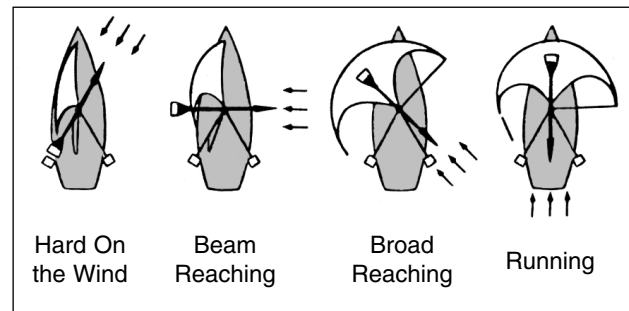

Tips on Using Your Windex 10.Sport

- Prior to unstepping your mast, take your Windex down first.
- Periodically check the assembly screws holding your Windex together. If you assembled your Windex with Loctite® or used silicone seal on the threads, the possibility of the unit unscrewing in use from vibration is eliminated.
- Lubrication is never needed, but years of salt or dirt build-up should be rinsed off with fresh water occasionally.

Replacement Parts

Replacement parts are available from your local dealer or Davis Instruments:

- #3101 Spare Vane only
- #R3100B Set Screw
- #R3100C Reference Tabs (2)
- #R3100D Index Holder with Clips
- #R3102 Extra Reference Tab Assembly
- #R3103 Extra Supporting Shaft
- #R3104 Extra Mounting Socket
- #3125 Extra J-Base for Windex 10.Sport

Accessories Available for Windex 10.Sport...

Windex Light

Makes viewing your Windex 10.Sport easier at night. Waterproof and non-corroding. Draws just 120 ma current.

#3200

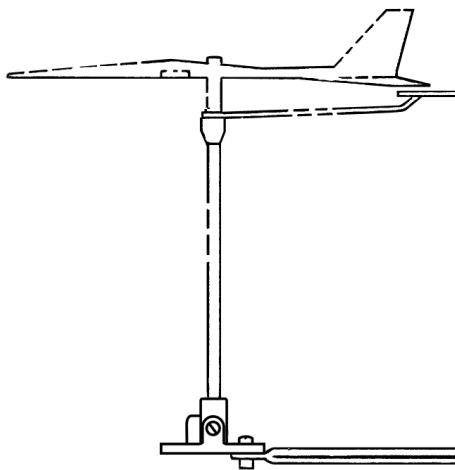
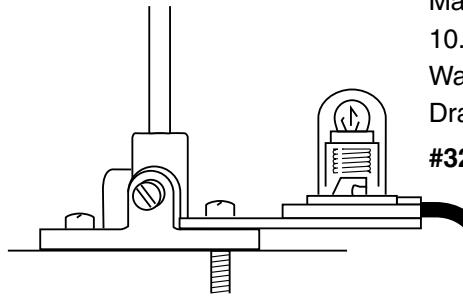

Universal Masthead Mount

Lets you extend your Windex 10.Sport away from masthead obstructions. The 13" (33 cm) arm comes with hardware allowing top or side mounting and offset angles up to 20°. Can be used with Windex Light (#3200).

#1705

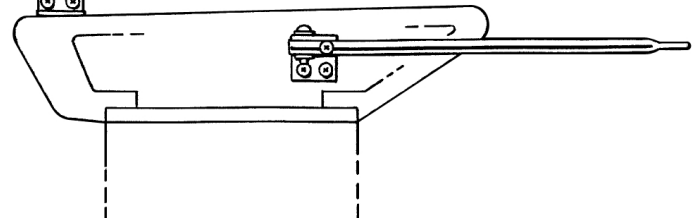

The Complete Windex® Line...

Windex, the famous wind direction indicator for sailboats, is the standard on most mastheads around the world. Models available for every sailor's needs:

- #3120 Windex 10.sport — 10" (25 cm) vane . . . for small boats and dinghies
- #3150 Windex 15 — 15" (38 cm) vane the choice for most sailors
- #3160 Windex AV — 15" (38 cm) vane for mounting on whip antennas, combining two installations in one
- #3170 WindexXL — 23" (58.4 cm) vane for boats over 40 feet (12 m)

Davis Instruments

3465 Diablo Ave., Hayward, CA 94545 U.S.A.
Phone (510) 732-9229 • Fax (510) 732-9188
info@davisnet.com www.davisnet.com