

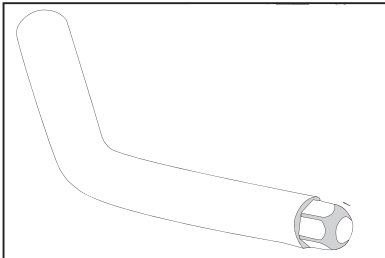

## Striker Base Gunnel Mount

Thank you for purchasing a quality Taco Marine product. As a family-owned business since 1959, Taco Marine takes pride in offering the highest quality products with excellent customer service. We stand behind our products 100%. Please visit our website, [TacoMarine.com](http://TacoMarine.com), for more detailed information on a wide variety of Sport Fishing products.

### Contents



A: 2 - Arm

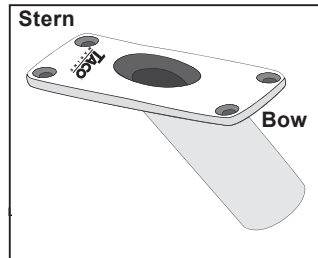

B: 2 - Base

### Recommendation

#### Tools Needed:

- Electric Drill with 5/16" Drill Bit
- 3/16" Allen Wrench
- 1/2" Crescent Wrench • Hole Saw

#### Recommended Hardware:

- Bolts = 18-8 Stainless Steel 1/4"-20 Phillips Oval Head Qty = 8 (Length of the Bolts will be determined by the thickness of the gunnel or flat surface being installed on boat)
- Nuts = 18-8 Stainless Steel 1/4"-20 Nylon Insert Lock Nuts Qty = 8
- Washers = 18-8 Stainless Steel Flat Washers Qty = 8 (Lock Washers are recommended to prevent hardware loosening from excess vibration on boat)

### Assembly Instructions

1. The lower base tube is at a 45° angle. The ellipse hole should be cut at 45° to the gunnel or other mounting surface. The gunnel mounting plate should be inserted through the gunnel with the tube towards the stern. Enlarge the template ellipse with file as necessary to get a good fit.

2. Use wide masking tape to protect mounting surface of base location prior to marking out for ellipse and before drilling. This helps prevent damage from drill slippage. Mark and drill the area with a hole saw. Drill bolts only after elliptical hole is made and base is positioned correctly and flat to the mounting surface.  
**F16-0150-F = use 2" hole saw**  
**F16-0212-F = use 1-1/2" hole saw**
3. Use a marine sealant between the mounting surface and the base.
4. Use only high quality stainless steel fasteners. Taco Marine recommends through-bolting if possible, and the use of backing plates (not included) on gunnels that are 3/4" or less for mounting surface reinforcement. The gunnel mounted Striker Bases are installed with the Taco Marine logo facing the stern of the boat (as shown in Figure 1).

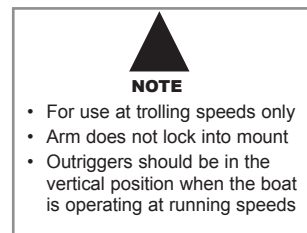
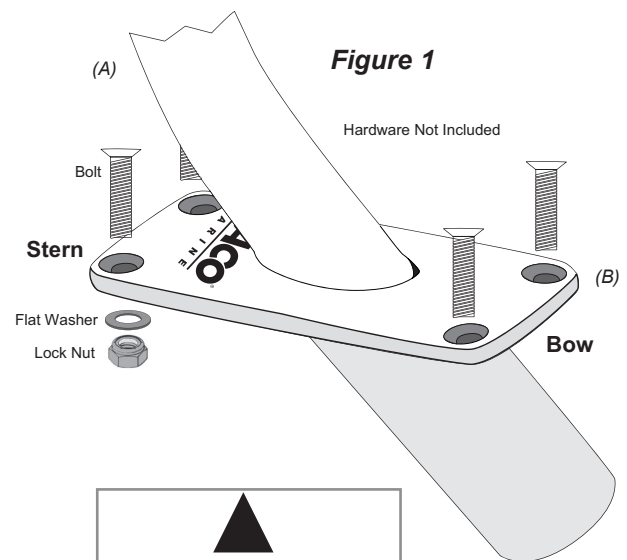

### CARE INSTRUCTIONS

Rinse your Taco Marine Striker Base Gunnel Mounts with fresh water and marine-grade boat soap after each use. Do not wax or use caustic cleaning agents on any of the components as that promotes corrosion.



# Drill Template F16-0150

*Note: Please print at 100% for accurate sizing. Slight scaling may still occur. Therefore, before drilling, it is recommended that all template dimensions are measured for accuracy. Use as a drilling template only after reviewing dimensions.*



**Do not drill bolts until the lower base is flush to the deck surface.**

**The gunnel mounting plate should be inserted through the gunnel with the tube towards the bow.**

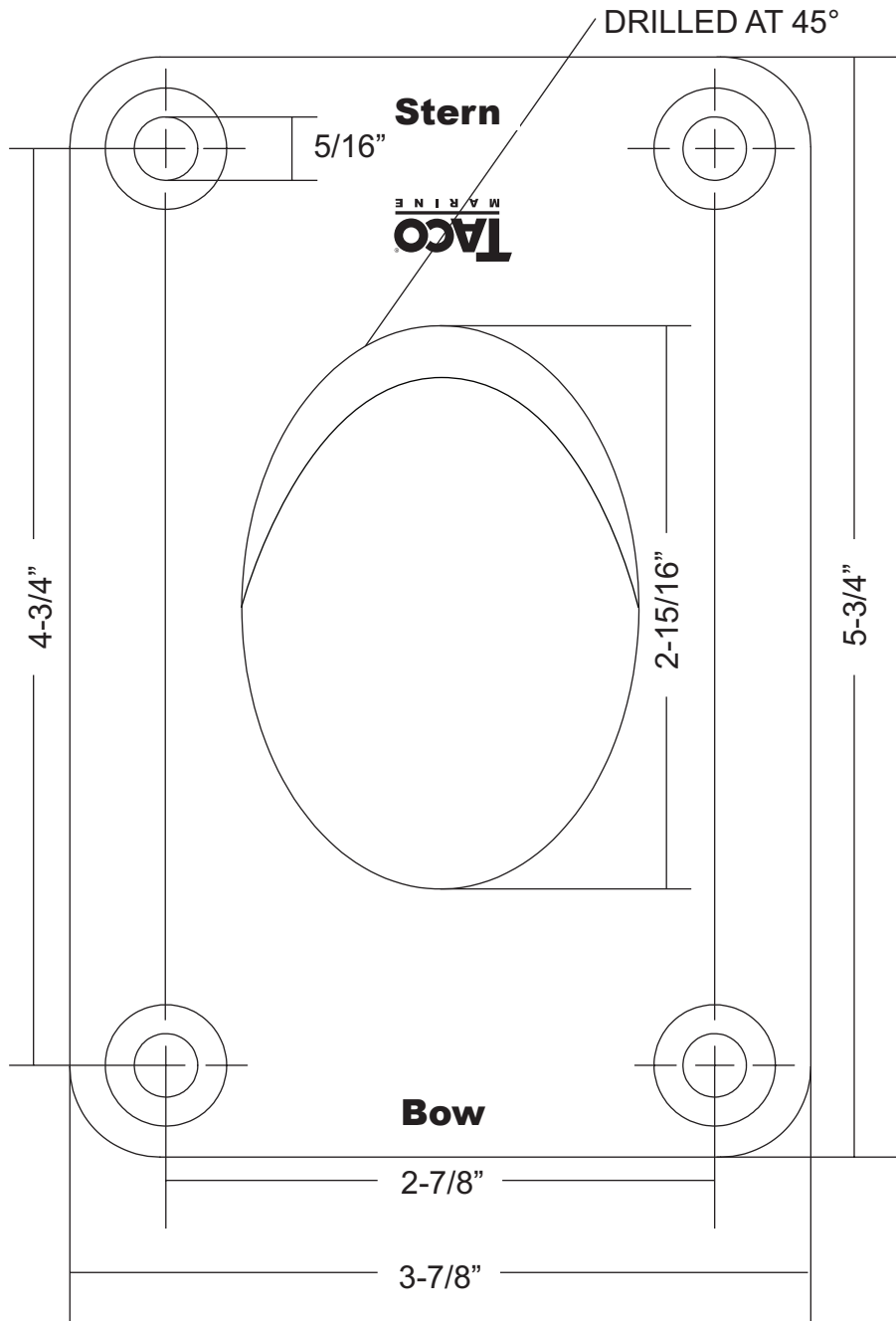
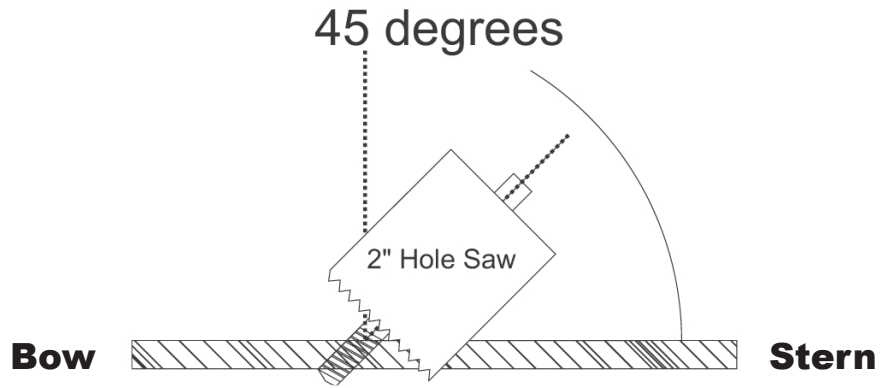



# Drill Template F16-0212

*Note: Please print at 100% for accurate sizing. Slight scaling may still occur. Therefore, before drilling, it is recommended that all template dimensions are measured for accuracy. Use as a drilling template only after reviewing dimensions.*



**Do not drill bolts until the lower base is flush to the deck surface.**

**The gunnel mounting plate should be inserted through the gunnel with the tube towards the bow.**

